



STERLING
TRUCKS

The New Sterling Crew Cab

The newest and largest

Construction. Municipalities. Fire fighters. Utilities. When there's work to be done, Sterling has been the smartest choice.

Now, when there's even more work to be done, the new Sterling® Crew Cab—available on Acterra and the L-Line—is ready to take it on. It's the latest example of what we mean when we say, nothing works like a Sterling truck.

The new Crew Cab is 15" longer on the inside—with 12" more rear seat leg room—than any market competitor.

The flat floor—no floor humps—and concave roof combine to provide ample head and leg room to help a full crew of five feel comfortable.

Standard cab air suspension, optional air ride driver and passenger seats and full-width three-person rear bench seats help guarantee driver comfort. Although the work may be hard, the ride will always be easy.

A monocoque, all-welded steel construction, reinforced with galvanized steel parts, means that your new Sterling Crew Cab is not only ready to handle today's job, but tomorrow's and tomorrow's and tomorrow's.

See your Sterling dealer for the whole story. And visit us at www.sterlingtrucks.com



Cab Dimensions

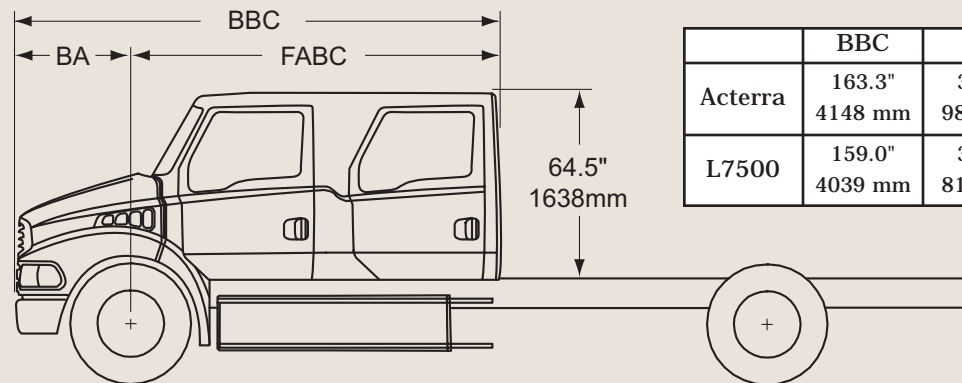

	BBC	BA	FABC
Acterra	163.3" 4148 mm	38.8" 985 mm	124.5" 3163 mm
L7500	159.0" 4039 mm	32.0" 812 mm	127.0" 3227 mm

One new cab...two truck models

Acterra and the L-Line enjoy an industry-wide reputation for driver satisfaction, performance and reliability. The new Crew Cab option adds a whole new dimension of versatility within markets where cab size is a prime requirement.



Interior Crew Cab Features

- Crew Cab has 12" more rear seat leg room over its nearest competitor...and is 15" longer, from the front of the cab to the rear interior wall.
- A flat floor (with full-length and full-width rubber matting) and concave roof combine to provide 56" floor-to-ceiling headroom.
- Standard full-width 3-person Bostrom bench seat, with ample shoulder room.
- Seat belts for rear seat: 2 outboard shoulder belts and 1 lap belt for the middle.
- Standard rear air-cab suspension.
- Optional front and rear heating/air conditioning.
- Available Blue Block Insulation Package.
- Available Base Oasis Tan or Oasis Tan interior trim.
- Trim level matches front cab specifications.
- Optional SCBA seating for fire and rescue applications
- Optional power windows and locks



Sterling TufTrac®

For on/off-road applications, spec' Sterling's proprietary TufTrac, our severe-duty 6-rod vocational suspension.

TufTrac combines taper leaf springs and a rubber elastomer center pivot to achieve extraordinary articulation where it's important to traverse bumps, ridges and washboards without bottoming out.

One of the lightest suspensions on the market, TufTrac maintains nearly equal axle loads when fully articulated, maximizes ground clearance.

TufTrac requires no lubrication, regular preventive maintenance or special tools.



Easy Engine Access

The easy-opening Acterra and L-Line aerodynamic hoods tilt a full 70 degrees. The splash shields swing up and out of the way, providing unrestricted access to the engine compartment for easy maintenance and servicing of fluid levels, hoses, alternators, headlamps and other components.

The optional radiator-mounted grille stays put to retain tilt-hood servicing convenience with front-mounted PTOs.



Easy Cab Entry and Exit

Full-length, low, two-step design is off-set, like stairs for easy climbing.

Four-door cab entry grab handles are ergonomically placed to help make cab entry easy and safe.

You'll like the way we work.™



For the Sterling Dealer nearest you, call 1-800-STL-HELP

www.sterlingtrucks.com

Some specifications and features shown or mentioned in this brochure are optional and are available on request at extra cost. Specifications are subject to change without notice. Sterling Trucks is registered to ISO 9001. Sterling Trucks, Willoughby, OH, 44094. Sterling Trucks is a member of the Freightliner Group. Copyright ©2003, Freightliner LLC. All rights reserved. Freightliner LLC is a DaimlerChrysler Company. Litho in U.S.A., MMS-55448, 09/03, **ST/MC-F-181**

AirLiner™, TufTrac® and Fleet Assistant® are trademarks of Freightliner LLC.

Sterling Crew Cab