



The Reliable and Flexible Acterra™

Get crews of three in and out of emergency situations faster and easier with Acterra™, the new medium-duty vehicle from Sterling.

In an emergency, every second counts. That's why you can depend on the new Acterra from Sterling.

No other truck in its class is as maneuverable as Acterra. Its 38.8-inch setback Meritor Widetrack front axle results in a 50-degree wheelcut angle.

No other truck in its class has a more durable, roomy, occupant-friendly cab. It not only seats three comfortably, but for windshield size and overall visibility, Acterra is best-in-class.

Acterra offers diesel power from Caterpillar, Cummins and Mercedes-Benz — including a specially rated 350 hp. emergency service Cummins.

Acterra...comfort and reliability in a premium medium duty truck from Sterling.



Emergency Service Chassis

ACTERRA™

8500...High-Capacity Pumpers and Tankers

The Class 8 Acterra with special engine ratings; standard ABS; front axle ratings from 10,000–18,000 lbs.; single rear axle ratings from 20,000–30,000 lbs.; tandem rear axle ratings from 34,000–46,000 lbs.; factory pusher axles and GVW's up to 90,400 lbs.

7500...Mid-Capacity Pumpers, Tankers and Rapid EMS

The Class 7 Acterra with up to 12,000 lb. front axles; one- and two-speed single rear axles up to 23,000 lbs.; standard hydraulic brakes with ABS and GVW's up to 35,000 lbs.

6500...EMS and Ambulance

The Class 6 Acterra with up to 10,000 lb. front axles; one- and two-speed 17,500 lb. rear axles; standard hydraulic brakes with ABS and GVW's up to 26,000 lbs.

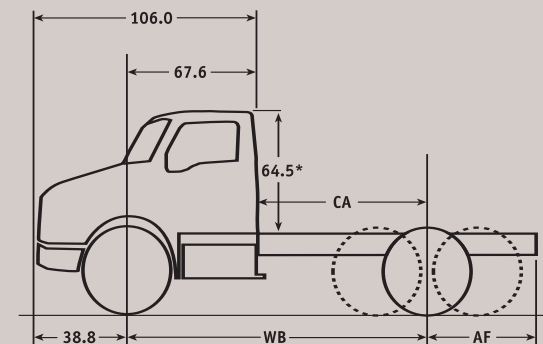

No two emergencies are alike...

Neither is Acterra. Every emergency is different.

So are the needs of every end-user. Acterra has been engineered and designed for flexibility and customization, offering a wide variety of engines, transmissions, wheelbases, front-frame extensions and custom chassis offerings.

Maneuverability. The 38.8-inch setback Meritor Widetrack front axle results in a 50-degree wheelcut angle.

Modular Cab Construction. Welded panels of galvanized steel provide high strength, durability and resistance to corrosion. SMC composite doors resist corrosion and denting.

Electrical. The robust design is best-in-class. Color coding and numbering provides for easy and convenient trouble shooting. Electrical taps on the chassis wiring harness eliminate the need for splice-and-tape body accessory installation. Alternators are available up to 270 amps.

Custom chassis offerings.

Clean cab-to-axle dimensions and smooth frame tops make for easy body mounting.

Custom frame punching guarantees your specs will be met.

Wheelbases can be spec'd to your precise needs.

Visibility. Shaped for extraordinary downward visibility, the strong, corrosion-resistant fiberglass tilt hood opens wide for easy, walk-up engine access.

Front frame

extensions, integral or bolt-on, are offered in a variety of sizes.



Specifications Are Available To Meet Every Emergency Service Need

Engines

Caterpillar 3126B from 175-330 hp
Cummins ISB from 185-275 hp
Cummins ISC from 225-350 hp
Mercedes-Benz from 170-300 hp

Transmissions

Manual: Eaton Fuller Direct Drive 5-, 6-, 7-, 9-, 10-Spd.; Overdrive 6-Spd., AutoShift 6-, 10-Spd.; TTC 7-Spd.
Automatic: Allison AT-545, MT-643/653DR, IMD-3060P/3560P/3066P, 1000/2000/2400

Front Axle (lbs.)

Meritor 8,000-20,000

Front Suspension (lbs.)

7,000-18,000

Single Rear Axle (lbs.)

Meritor 15,000 to 30,000 ratings (1- and 2-speeds)

Rear Suspension, Single (lbs.)

15,000 to 31,000 ratings
Taperleaf, Flat Leaf, Sterling AirLiner™ and Reyco

Tandem Rear Axle (lbs.)

Meritor 34,000 to 46,000 ratings

Tandem Rear Suspension (lbs.)

34,000 to 46,000 ratings
Flat Leaf, Taperleaf, TufTrac™, AirLiner™, Chalmers and Hendrickson

Brake System

Bosch Hydraulic Disc; Bosch Hydraulic Disc with Air Supply; and Air

Anti-Lock System

Meritor WABCO

Frame Rails

Standard: 6500 and 7500: 1/4" x 3" x 10" (10 SM)
8500: 5/16" x 3" x 10-1/8" (12.5 SM)
Other frame rail options available for all models

Fuel Lines

Sterling EquiFlo® Inboard Fuel System

Your Sterling/Acterra Dealer

Your Sterling/Acterra Dealer can provide you with details regarding the proper specifications for your application. Sterling designed Acterra to help ensure that mounting of emergency service bodies is as simple as possible.

For the Sterling/Acterra Dealer nearest you, call 1-800-STL-HELP

www.sterlingtrucks.com

Some specifications and features shown or mentioned in this brochure are optional and are available on request at extra cost. Specifications are subject to change without notice. Copyright ©2000, Sterling Truck Corporation, Willoughby, OH, 44094. All rights reserved. Litho in U.S.A., 11/00, SS-0127



Freightliner is a DaimlerChrysler Company

ACTERRA Emergency Service Chassis