



STERLING
TRUCKS

Call Peck Road At:
(562) 692-7267

Or Visit www.peckroad.com

Beverage Favorites

The only truck stop a beverage hauler is likely to pull into is the one behind the High Street party store. A tried and true city slicker, it sees more back alleys than open road.

Acterra and the **L-Line** are Beverage favorites, ranking high in driver satisfaction for ease of entry and egress. Roominess. Outstanding visibility, maneuverability and ride.

Their **HVAC system** is among the best in the industry, offering high volume, uniform air flow throughout the cab.

Acterra, with a Class 5-8 rating and a 106" BBC, is a medium-duty truck designed for **best-in-class ride and handling**, maneuverability and toughness.

The chassis is clean and tough and offers a specially reinforced frame for Beverage application.

L-Line trucks and tractors are the heavy duty performers. Lighter, tougher frames offering over 5 million RBM provide strength and durability. Available in four BBC's.

The short-nosed 101" L-Line with excellent visibility and ease of operation, offers a unique Beverage muffler package.



General Specifications

BBC: Acterra: 106"; L-Line: 101"/111"/113"/122" **GVWR:** Acterra: 18,000 lbs. - 64,000 lbs.; L-Line: 60,000 lbs.

Engines:

- Mercedes-Benz MBE 900: 190-330 hp MBE 4000: (L-Line) 350-450 hp
- Caterpillar 190-330 hp 190-550 hp (L-Line)
- Cummins 225-350 hp (Acterra)
- Detroit Diesel Series 60: 350-500 hp (L-Line)

Transmissions:

- Manual:
- Eaton Fuller Direct Drive: 5-10-speed; Overdrive: 6-11-speed (Acterra) 5-15-speed; Overdrive: 6-18-speed (L-Line)
 - Mercedes Direct Drive: 6-speed; Overdrive: 6-speed (Acterra)
- Automatic:
- Allison: 1000, 2000, 2400, 3000, 3200, 3500, MD, HD
 - Eaton Fuller Autoshift: 6-10-speed (Acterra) 10-18-speed (L-Line)
 - Meritor FreedomLine: 12-16-speed (L-Line)
 - Ultrashift: 6-10-speed (Acterra) 10-speed (L-Line)

Axles:

- Front: 8k-18k (Acterra) 10k-20k (L-Line) Meritor, Steertek
- Rear: 13k-46k (Acterra) 17k-52k (L-Line) Meritor, Fabco

Suspensions:

- Front: 8k-18k (Acterra) 9k-20k (L-Line) Taper-leaf, Multi-leaf, Flat-leaf
- Rear: 10k-46k (Acterra) 18k-52k (L-Line) TufTrac® 2, AirLiner™, Taper-leaf, Multi-leaf, Flat-leaf, Hendrickson

Because no two customers' operations are the same, Sterling offers extensive custom-engineered options and configurations. We engineer the right truck for your job, so you can get it done faster and easier.

Nothing works like a Sterling truck

Work hard. Ride easy.

For whatever line of work you're in, nothing works like a Sterling truck. It's tough and reliable on the job...easy on the driver. By design.

Driver Features:

Easy Cab Entry/Exit (Acterra shown)

- Full-length, low, two-step design is off-set like stairs for easy climbing.

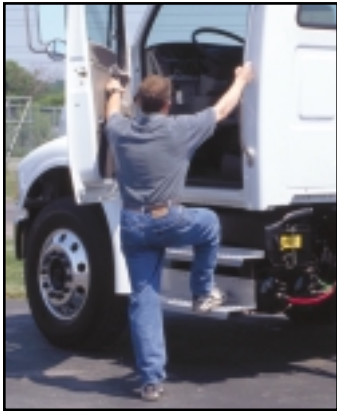

Tight Turning Radius (Acterra shown)

- An impressive wheel-cut angle results in a smaller turning radius for improved maneuverability.



Frames and Suspensions:

Lighter, Tougher Frames

- Extra-high tensile bolted 120,000 psi frames are stronger and lighter than previous offerings—with over 5 million RBM rating (L-Line) and up to 3.7 million RBM (Acterra).
- Optional premium HUCK® bolt fasteners enhance durability and eliminate retorquing in critical areas.

AirLiner™ Suspension

- 12k front/46k rear rating
- Premium cab comfort
- Helps protect cargo

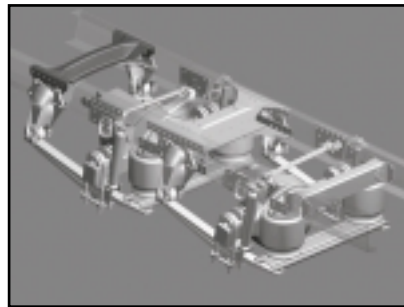

Component Locations:

Fuel Tanks

- Aluminum fuel tanks are mounted under-cab, for maximum ground clearance and a clean CA.
- Aluminum tanks have a 30% thicker wall than steel and are more corrosion-resistant.

Interiors:

Seat trims

- Base:
 - vinyl seats w/vinyl insert
- Optional:
 - vinyl seats w/cloth insert
 - cloth seats w/cloth insert
 - extra-tough Mordura seat covers (shown)



Several Seat Options:

Sterling EzyRider™

- Improves ride, comfort and stability.
- Adjustable firmness and lumbar support.
- Reduces fatigue.
- Convenient Seat Position Indicator.
- Air suspension options include heel protection, map pockets and arm rests.



You'll like the way we work.™



Some specifications and features shown or mentioned in this brochure are optional and are available on request at extra cost. Specifications are subject to change without notice. Sterling Trucks is registered to ISO 9001. Sterling Trucks, Willoughby, OH, 44094. Sterling Trucks is a member of the Freightliner Group. Copyright ©2003, Freightliner LLC. All rights reserved. Freightliner LLC is a DaimlerChrysler Company. Litho in U.S.A., MMS-55630, 09/03, ST/MC-F-195

AirLiner™, TufTrac® and Fleet Assistant® are trademarks of Freightliner LLC.

**Call Peck Road At:
(562) 692-7267**

Or Visit www.peckroad.com